

Diamond Wheel Grinding 101

Understanding and controlling the grinding parameters are essential prerequisites to machining advanced ceramics.

by **Thomas R. Shearer**, Director of Business Development, PremaTech Advanced Ceramics, Worcester, Mass.

Most engineers and designers who work with advanced ceramic components know that producing a prototype or small lot production part usually requires some significant grinding to achieve the final shape. As the part is proven out in its intended application, production techniques that produce an almost near-net-shape are then employed, including casting, cold compacting, injection molding, sintering, hot pressing and hot isostatic pressing. These processes, even if they are capable of producing a nearer-net-shape part, typically are not capable of producing a part to tight dimensional toler-

ances or fine surface finishes. Thus, to meet exacting dimensional requirements, specific surface finishes or other geometrical requirements, final machining is required of the as-fired ceramic.

The geometry, surface integrity, tolerance, spindle power, work chippage and consistency are all parameters that one has to consider before engaging the grinding wheel to the work piece. All of these characteristics determine the retained strength after finishing and, ultimately, the overall cost. Machining of a particular product depends on its material properties and end characteristics and can be accomplished by several methods, such as conventional dia-

mond wheel grinding, creep feed grinding, ultrasonic machining, EDM processing, etc. This article will focus on conventional diamond wheel grinding.

Fundamentals

It is important to recognize that the parameters applicable to grinding other hard materials, such as tungsten carbide/cobalt grades, are not necessarily applicable to grinding advanced ceramics. Fundamentally, this is due to the differences in the physical properties of tungsten carbide and advanced ceramics.

Tungsten carbide/cobalt material, though brittle, exhibits some degree of plastic

Diamond Wheel Grinding

Table 1. Factors concerning diamond wheel selection.

Factor	Considerations
Wheel Size	Determined by the grinding machine and spindle rpm available. The surface speed for normal grinding is between 4500 to 9000 fpm.
Metal Bond	For softer, large-grain-size, porous refractory ceramics and Al_2O_3 . Can use higher tool pressure and is long lasting.
Resinoid Bond	For harder advanced or technical ceramics. Can use a lower tool pressure with minimal surface damage, allowing for a finer surface finish.
Vitrified Bond	For harder advanced or technical ceramics. Can use a higher tool pressure for slow grinding applications and maintains good dimensional control. Generally more costly.
Diamond Size	Coarse 80-150 grit for roughing, fine 220-325 grit for finishing, extra-fine 400- 1200 grit for super-finishing.
Shape/Strength	Shape and strength (friability) must be closely matched with the bond system to obtain as nearly as possible a “self-dressing” wheel. Work with the wheel distributor/manufacturer to obtain the best match.
Concentration	In grinding tungsten carbide/cobalt grades, traditionally the higher the concentration, the harder acting the wheel. This does not appear to be the case for a fine-grit (325), high-concentration (125) friable diamond wheel used with the proper feed rate and diamond exposure relationship in grinding hot pressed Si_3N_4 and B_4C .
Diamond	Must be uniform throughout the useful life of the wheel. The wheel distributor/manufacturer must be able to define a process that ensures uniform diamond distribution.
Truing & Dressing	Once the wheel is mounted on the machine, it should be trued using a device such as the brake-controlled wheel truing device. After truing, it should be carefully dressed using an abrasive (SiC) dressing stick of a grit size smaller than the diamond grit. The purpose is to expose diamond length (D_L) at least equal to 50 to 60% of the diamond particle size.

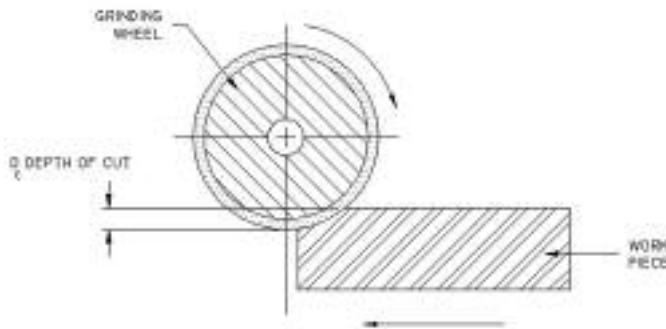

Figure 1. The grinding process. The depth of cut is exaggerated for illustration purposes.

deformation when subjected to a high enough stress. Advanced ceramics, on the other hand, show no plastic behavior and are incapable of relieving an applied stress by localized deformation. The applied stress causes microcracks or residual stress, resulting in unpredictable failure.

The grinding process often generates such stress, and the need to control it is far greater in advanced ceramics than in tungsten carbide/cobalt grades. By selecting a wheel containing smaller but sharper abrasive grains, increasing wheel speeds, decreasing the depth of cut and reducing traverse rates, induced stress can be minimized.

Diamond wheel grinding, in an overly simplified way, can be described as removing undesirable portions of material from a part by subjecting it to repeated overlapping contact with a rotating diamond wheel (see Figure 1). To understand the difference between grinding tungsten carbide and advanced ceramics, it is necessary to look at the grinding process and the grinding wheel from a fundamental level.

During the grinding process, the rotating diamond wheel is brought down on the work piece so that the tips of the exposed diamond particles barely touch the surface to be ground. At this start-

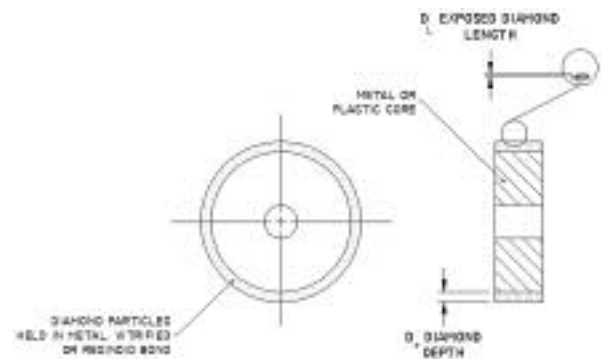

Figure 2. A typical diamond wheel contains uniform but randomly distributed diamond particles.

ing point, the work piece is subjected to either a reciprocating or a rotating motion, and the wheel is dropped further by an amount equal to the depth of cut (D_c). The process is repeated n times until the desired amount of material equal to $n \times D_c$ is removed.

Wheel Details

A diamond wheel, in a simplified version, consists of a circular metallic or plastic core. The outer rim of this core is composed of a metallic or resinoid layer $1/16$ in. or thicker, which contains uniform but randomly distributed diamond particles (see Figure 2). The bond system, whether metal, vitrified or resinoid, and the characteristics of the diamond particles regarding friability, shape and other factors, vary among the wheel manufacturers. Table 1 lists the important factors to be considered when selecting a diamond wheel. Despite greater wheel wear, resinoid wheels are commonly used because of their faster stock removal rate at lower tool pressures.

Almost all diamond wheel manufacturers consider specific information regarding their diamond and bond characteristics to be proprietary. However, for any diamond wheel to remain sharp and free cutting throughout the grinding cycle, the bond system

Table 2. Diamond grit size.

Grit Size	Particle Size		Expected Surface Finish (RA)
	Microns	Inch	
80	267	0.0105	24-36
150	122	0.0048	14-16
180	86	0.0034	12-14
220	66	0.0026	10-12
320	32	0.0012	8
400	23	0.0009	7-8
600	14	0.0006	2-4
1200	3	0.0001	1-2

Table 3. Diamond concentration.

Standard Diamond Concentration	Typical Vol. % of Diamond	Carats/in. ³
100	25.00	72
75	18.75	54
50	12.50	36
25	6.25	18

Table 4. Surface speed chart.

Wheel Diameter (inches)	Surface Speed (fpm)	Wheel rpm
5	4500	3450
6	5300	3450
7	6300	3450
8	7250	3450
10	4600	1750
12	5500	1750
14	6400	1750
16	7300	1750

Table 5. Suggested wheel specifications.

Material to be Ground	Roughing		Finishing	
	Grit	Concentration	Grit	Concentration
Hot Pressed B ₄ C	180	100	320	125
Hot Pressed Si ₃ N ₄	150	100	320	100
Hot Pressed SiC	120	75	320	75
Sintered SiC	220	100	320	100
High-Density Al ₂ O ₃ , ZrO ₂	220	75	320	50
SiC Whisker Reinforced Al ₂ O ₃	150	75	320	75
Al ₂ O ₃	80	100	180	100

has to be abrasible enough to keep new particles exposed, but not so abrasible that the wheel must be replaced frequently.

In the grinding of tool steels or tungsten carbide/cobalt grades, both the work piece and the swarf particles help dress the grinding wheel during the grinding process. For advanced ceramics grinding, these conditions are just the opposite. The high hardness of the work piece and the small particle size of the swarf (under 5 microns) are not conducive to keeping the diamond wheel open.

Grinding Factors

As seen in Figure 1, if the wheel is fed into the work piece deeper than the exposed diamond length (i.e., if $D_c > D_L$), damage to either the grinding wheel or the work piece will result. In cases where $D_c = D_L$, a considerable amount of heat is going to be gen-



Typical parts finished by diamond wheel grinding. Photo courtesy of PremaTech Advanced Ceramics.

erated due to the rubbing that occurs between the work piece and the wheel bonding material. Coolant used for removing excessive heat will also not be very effective due to the collapse of annular space between the wheel and work piece.

Therefore, the ideal situation is when $D_c = \frac{1}{2} D_L$ and is maintained throughout the grinding range. In almost all types of grinding (reciprocating, cylindrical, centerless, etc.), the feed rate is maintained at the depth of cut per pass.

The greater the D_L , the greater the D_c can be, resulting in a higher rate of material removal. The limiting factor, of course, comes from the fact that to increase the D_L , coarser grit diamond particles must be used, which influences the surface finish of the part. Table 2 lists common grit sizes and the expected surface finishes attainable.

In a properly dressed diamond wheel, at least 50 to 60% of an exposed diamond particle should protrude beyond the bond surface. That is, $D_L =$ approximately 60% of the diamond particle size. One could therefore calculate from Table 2 that for an 80-grit wheel, D_L would be .0063 in., and the maximum feed rate should not exceed 0.003 in. per pass. For a 320 grit wheel, $D_L = .0007$ in., and the maximum feed rate should be 0.00035 in. per pass.

The process of grinding requires that the relative behavior between the grinding wheel and the work piece remain constant throughout the grinding cycle. As the exposed diamond particles wear and become dull during the grinding process, they either break into smaller segments, exposing new cutting facets, and/or completely break away from the wheel to expose new diamond particles. This would obviously depend on the number of diamond particles in the bond system and the relative strength of the particles and the bond.

The number of diamond particles for a given grit size in a wheel is defined by the diamond concentration number. Table 3 lists the common concentrations commercially available; however, each wheel manufacturer should be consulted to verify the diamond content for a given concentration.

Diamond Wheel Grinding

Among the many factors comprising the grinding process is the surface speed of the grinding wheel. This factor gets overlooked in many cases and can affect productivity. Table 4 lists the change in surface speed for a given spindle speed. As illustrated, a 38% decrease in surface speed results from changing the wheel diameter from 8 in. to 5 in.

Taking into account all the aforementioned factors, nothing beats operator experience when it comes to diamond wheel grinding of advanced ceramics. For example, it is known that hot pressed boron carbide and silicon nitride behave very differently than zirconia under the same grinding conditions, due to the different physical properties of the materials. Operator experience will dictate certain specific parameters, but Table 5 offers a general guide and starting point for machining some of the more common advanced ceramics.

In the Know

The functional reliability of an advanced ceramic component is greatly influenced by the machining process, especially in diamond wheel grinding. Understanding and



Nothing beats operator experience when it comes to diamond wheel grinding of advanced ceramics. Photo courtesy of PremaTech Advanced Ceramics.

controlling the grinding parameters are essential prerequisites to machining such materials. Using a trusted and experienced grinding source will help manufacturers minimize the variable of induced stress caused by diamond wheel grinding. 🌐

For more information on diamond wheel grinding, contact PremaTech Advanced Ceramics at 2 Coppage Dr., Worcester, MA 01603-1252; (508) 791-9549; fax (508) 793-9814; www.PremaTechAC.com.

References

1. R. Chand, K. Costello, T. Payne, "Finish Machining of Technical Ceramics," paper delivered at SME-Advanced Ceramics Conference, Rosemont, IL, 1990.
2. P. Annese, T. Vasilos, J. Annese, "Techniques for Machining Structural Ceramics," *Ceramic Industry*, September 1992, pp. 63-65.
3. J. Picone, "Scientific Approach Optimizes Results in Structural Ceramic Grinding," *Ceramic Industry*, September 1995, pp. 43-45.

